

PART NO	CABLE	COLOR CODE	DIM F	DIM B	DIM C	DIM D	DIM E	REMARKS
222191-1	M17-176-00002; NORTHROP 05A078-1	VIEW S	.143 [3.63]	.032 [0.81]	.054 [1.37]	.112 [2.84]	.047 [1.19]	19
222191-2	M17-176-00002; NORTHROP 05A078-1	VIEW S	.143 [3.63]	.032 [0.81]	.054 [1.37]	.112 [2.84]	.047 [1.19]	19
222191-3	TENSOLITE 24463/9P025X-2(LD) OR TENSOLITE 24463/9B017X-2(LD) (OBSOLETE)	VIEW U	.157 [3.99]	.050 [1.27]	.063 [1.60]	.140 [3.56]	.052 [1.32]	20 1
222191-4	M17-176-00002; NORTHROP 05A078-1	VIEW S	.143 [3.63]	.032 [0.81]	.054 [1.37]	.112 [2.84]	.047 [1.19]	
222191-5	TENSOLITE 24463/9P025X-2(LD) OR TENSOLITE 24463/9B017X-2(LD) (OBSOLETE)	VIEW U	.157 [3.99]	.050 [1.27]	.063 [1.60]	.140 [3.56]	.052 [1.32]	21 1
222191-6	PRELIMINARY NOT RELEASED FOR PRODUCTION							
222191-7	PRELIMINARY NOT RELEASED FOR PRODUCTION							
222191-8	RAYCHEM 10614	VIEW S	.174 [4.42]	.032 [0.81]	.054 [1.37]	.112 [2.84]	.047 [1.19]	

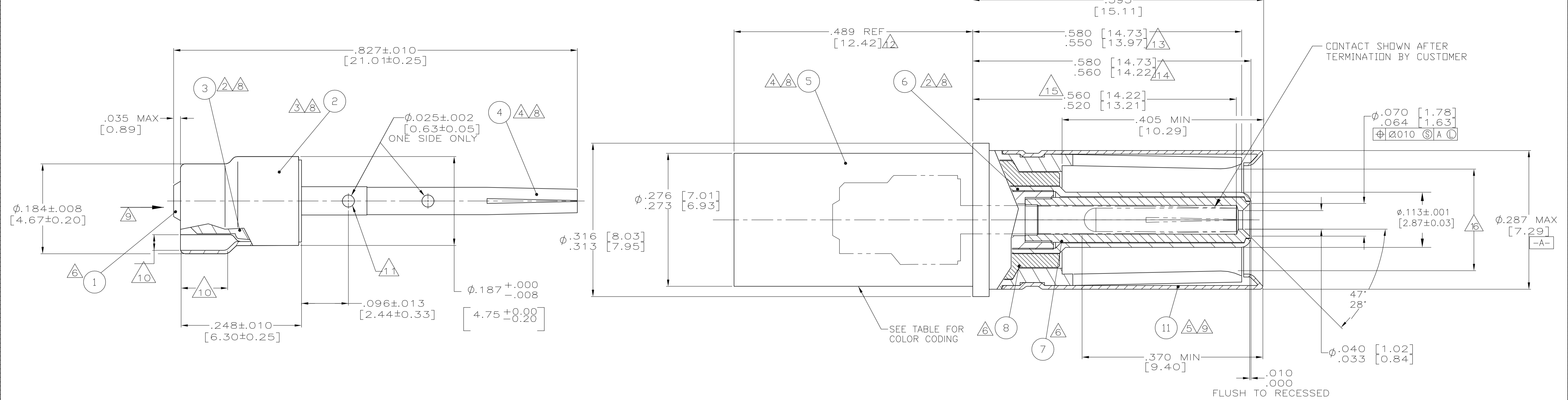

- 1 PRODUCT DESIGN TO MEET BOEING S280W552 DRAWING.
- 2 MAT'L: BRASS PER ASTM-B-16
- 3 MAT'L: COPPER PER ASTM-B-152.
- 4 MAT'L: BERYLLIUM COPPER PER ASTM-B-196.
- 5 MAT'L: STAINLESS STEEL PER QQ-S-766.
- 6 MAT'L: PTFE PER ASTM-D-1710.
- 7 MAT'L: FLUOROSILICONE MLDG. CMPD. PER ZZ-R-765.
- 8 FINISH: GOLD PLATE PER MIL-G-45204, TYPE 1, GRADE C, CLASS 1 OVER NICKEL .000050 [0.0013] THK PER QQ-N-290, CLASS 2.
- 9 FINISH: PASSIVATE PER QQ-P-35.
- 10 A .0285 [0.72] GAGE PIN MUST ENTER FOR A LENGTH OF .085 [2.16] MIN.
- 11 .028 [0.71] GD - .031 [0.79] NO GD GAGE WILL ENTER TO A DEPTH OF FIRST SIGHT HOLE.
- 12 .533 [13.54] MAX AFTER TERMINATION TO CABLE. TO END OF OUTER SOCKET CONTACT.
- 13 TO END OF INTERMEDIATE PIN CONTACT AND CENTER SOCKET INSULATOR.
- 14 TO END OF CENTER SOCKET CONTACT.
- 15 MATES WITH .218 #001 [5.53 #0.03] DIA PIN.
- 16 160 DP. FULL DIAMOND KNURL OVER THIS LENGTH.
- 17 COLOR CODE PER MIL-C-39029. COLOR CODE BANDS CAN BE LOCATED ANYWHERE BETWEEN THE .200 [5.08] MIN AND .005 [0.13] MIN DIMS.
- 18 BAG MARKED WITH CUST. P/N 05A076-1. (-1 & -2 ONLY.)
- 19 BAG MARKED WITH CUST. P/N S280W552-105, (FOR -3 ONLY.)
- 20 BAG MARKED WITH CUST. P/N S280W552-205, (FOR -5 ONLY.)
- 21

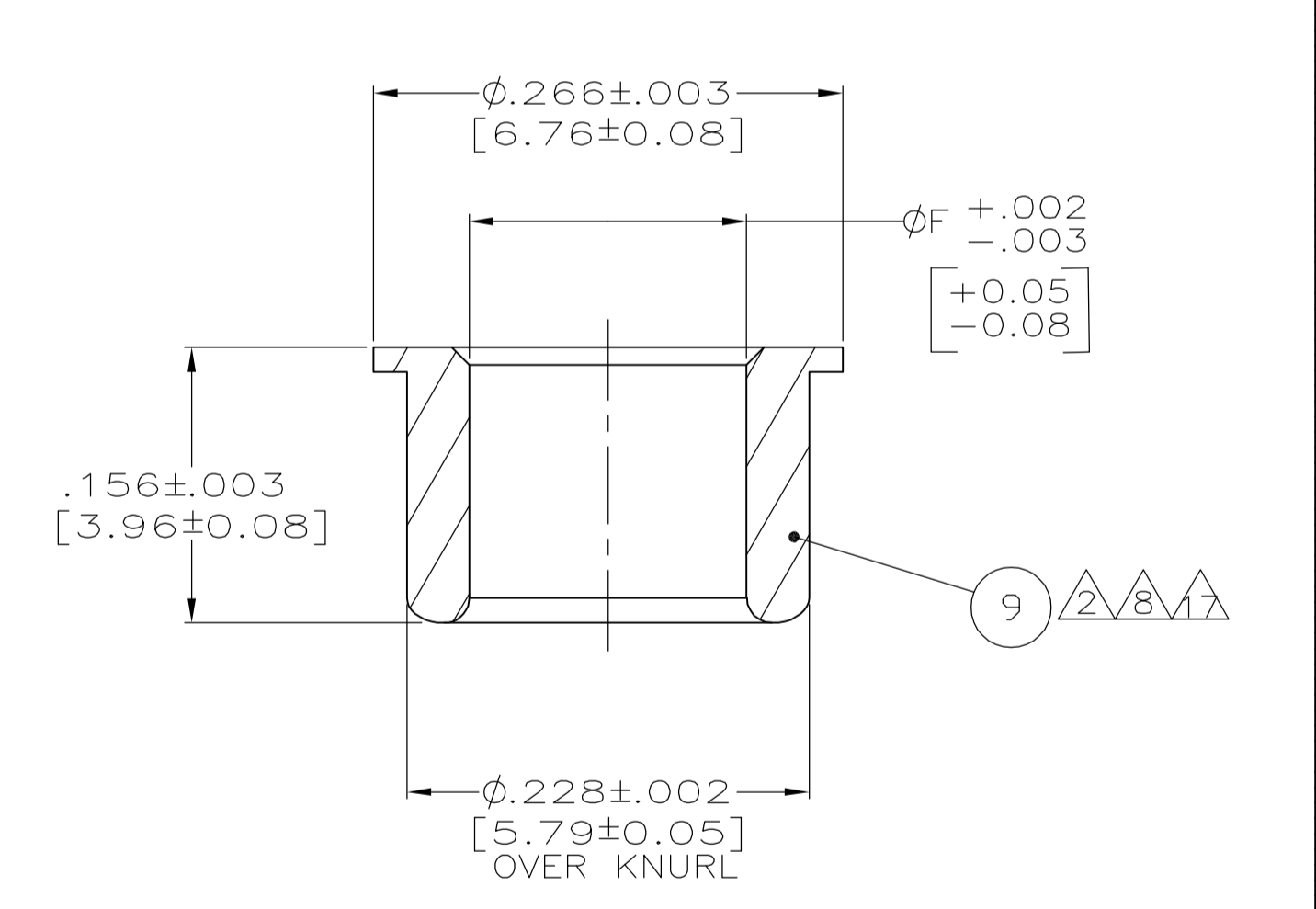
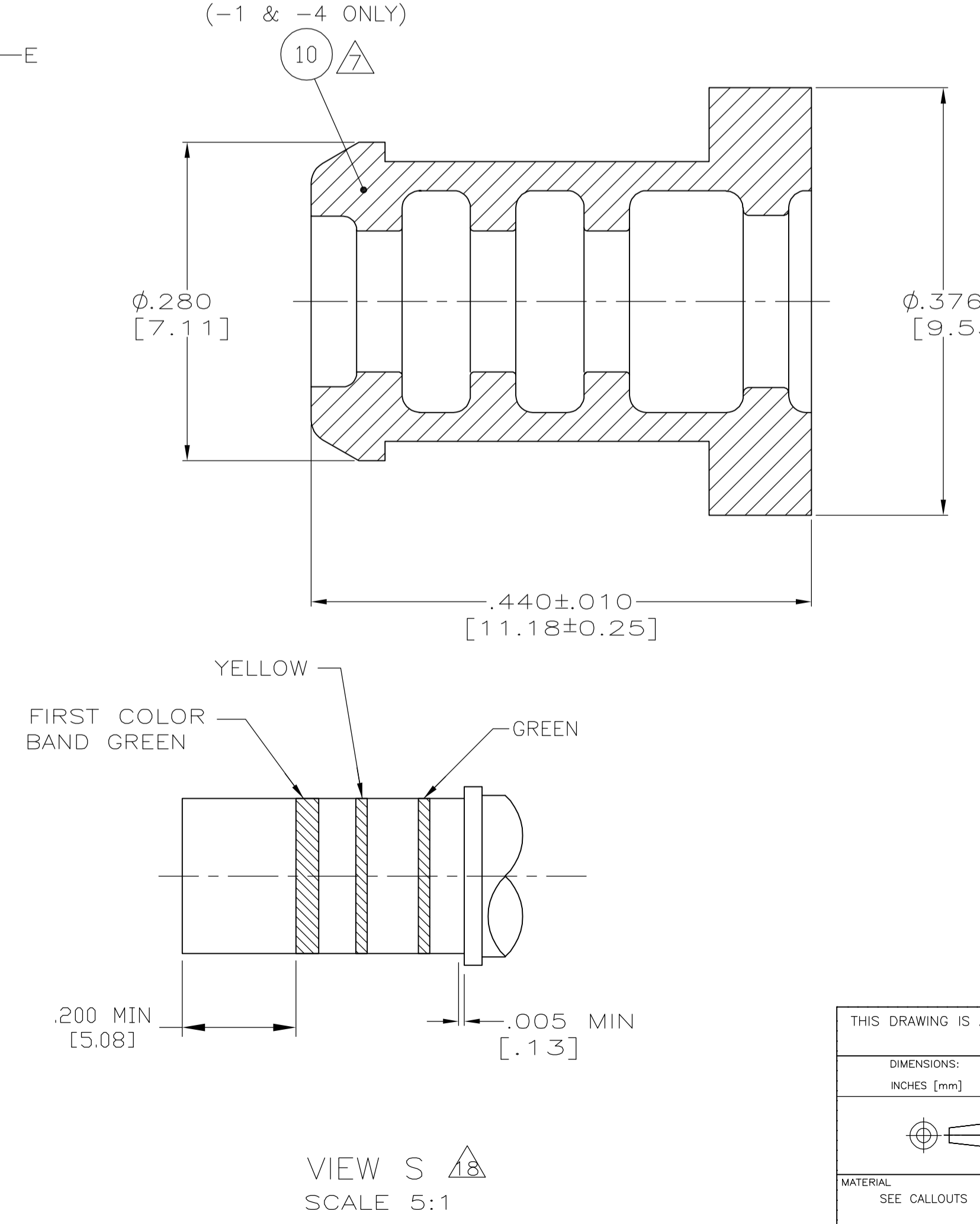
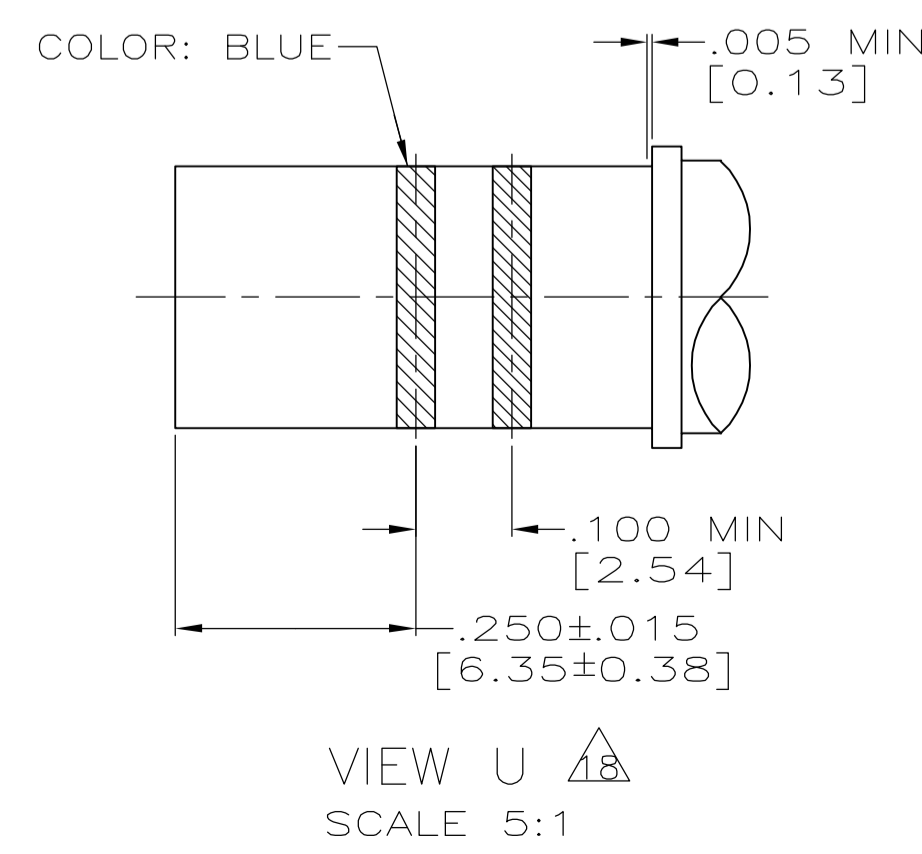
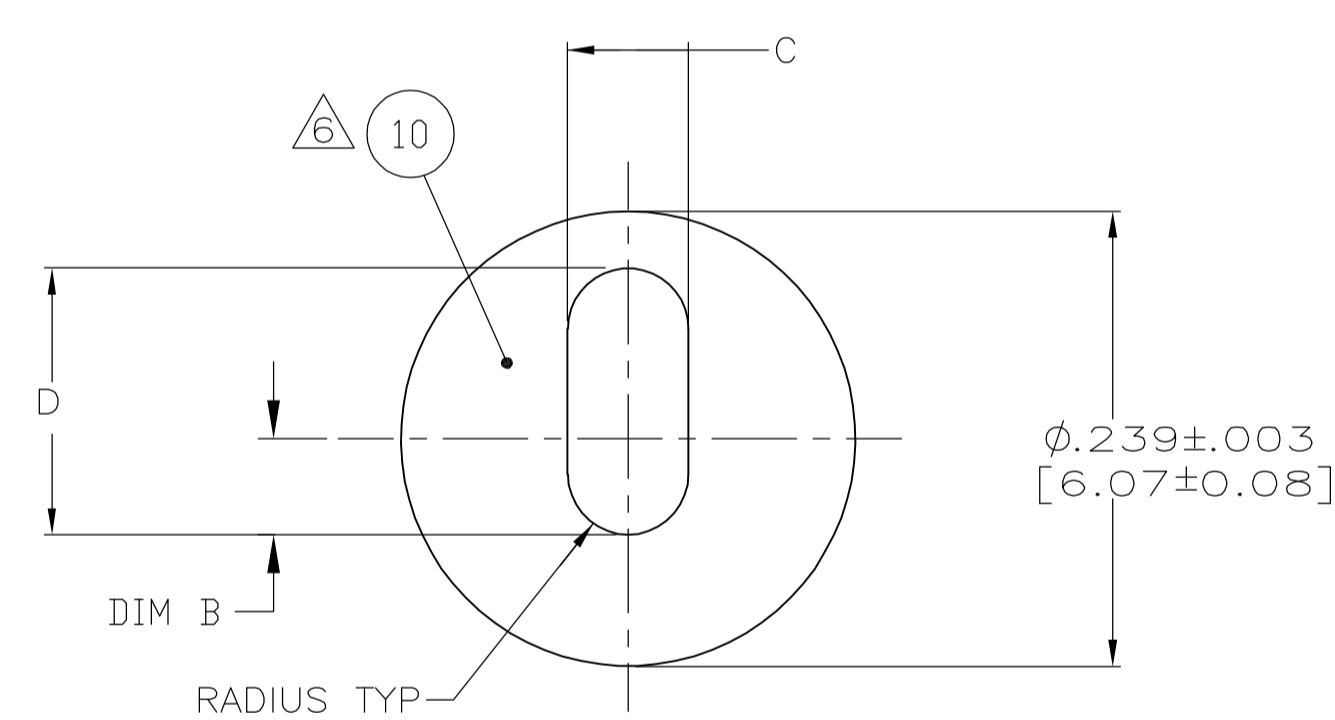

THIS DRAWING IS A CONTROLLED DOCUMENT.		DIN T. THOMPSON 10-26-94	AMP Tyco Electronics Corporation Harrisburg, PA 17105-3608	
DIMENSIONS: INCHES [mm]	TOLERANCES UNLESS OTHERWISE SPECIFIED:	CHK C. SHELLY 10-28-94	APVD C. SHELLY 10-28-94	NAME
0 PLC ± -	1 PLC ± -	PRODUCT SPEC	APPLICATION SPEC	SIZE
2 PLC ± -	3 PLC ± .006 [0.15]	WEIGHT	A1 00779	DRAWING NO
4 PLC ± -	ANGLES ± -	CUSTOMER DRAWING	00779	222191
MATERIAL SEE CALLOUTS	FINISH SEE CALLOUTS	SCALE 10:1	SHEET 1 of 1	REV L

SEALING PLUG	12
HOOD, SOCKET	11
BUSHING	10
FERRULE	9
DIELECTRIC, OUTER, FRONT	8
DIELECTRIC	7
CONTACT, INTERMEDIATE, SIZE 8	6
SHELL, OUTER, SOCKET	5
CONTACT, SOCKET	4
SHELL, CRIMP END	3
FERRULE	2
DIELECTRIC	1